

SIMULATION OF ESPRIT OF HUALONG SECONDARY PASSIVE RESIDUAL HEAT REMOVAL SYSTEM BY USING RELAP5

Li Feng

Science and Technology on Reactor System Design Technology Laboratory
ChangShun avenue 328, ShuangLiuCounty, ChengDu, CHINA
104122587@qq.com

ABSTRACT

A 3rd generation reactor called HuaLong is developed by China National Nuclear Corporation (CNNC). Secondary passive system (PRS) is designed to remove the residual heat during 72 hours after the reactor trips. To verify the ability of PRS system, the test facility ESPRIT is built in Chengdu which is 1:1 in height and 1/62.5 in power. Tests are consisted by three Steady-states and one transient. One model of RELAP5 mod3.2 is developed and used to simulate the steady and transient tests. The results of RELAP5 show consistent with facility results, but the early phenomenon during transients is different between RELAP5 and tests as RELAP5 underestimates the direct-contact condensation power.

KEYWORDS

RELAP5; ESPRIT; PRS; Direct-contact condensation

1. INTRODUCTION

HuaLong I reactor an advanced 3rd generation reactor, have been developed by China National Nuclear Corporation (CNNC). The design is based on CP1000, and upgraded according to Experience Feedback from Fukushima accident. The design has following features:

- ✓ Fully learn advanced design concepts of 3rd generation nuclear technology;
- ✓ meet the latest nuclear safety regulations, guidelines and standards;
- ✓ using active + passive safety design;
- ✓ based on proven, reliable technology and equipment;
- ✓ consider the Fukushima nuclear power plant accident experience feedback.

Compared to the traditional second-generation power plants, Major improvement of Hualong I design is using three passive systems to mitigate Beyond Design Basis Accident. They are PRS(Passive residual heat Removal System), PCS(Passive Containment cooling System) and CIS(core injection system).

The secondary passive residual heat removal system based on passive concepts is one of the means to remove the residual heat of the reactor, it can improve the ability of defense-in-depth, enrich mitigation measures to severe accident. It's designed to confirm the following function: In the event of SBO and the auxiliary feedwater system failure conditions, to export the decay heat of the core and heat stored in each device within 72 hours to maintain the reactor in a safe shutdown condition, to ensure the safety of the reactor and reduce the CDF (Core Damage Frequency).

To verify the ability of PRS system, the test facility ESPRIT is built in Chengdu which is 1:1 in height and 1/62.5 in power. Tests are consisted by three Steady-states and one transient. One model of RELAP5mod3.2 is developed and used to simulate the steady and transient tests. The results of RELAP5

show consistent with facility results, but the early phenomenon during transients is different between RELAP5 and tests as RELAP5 underestimates the direct-contact condensation power.

2. PASSIVE RESIDUAL HEAT REMOVAL SYSTEM

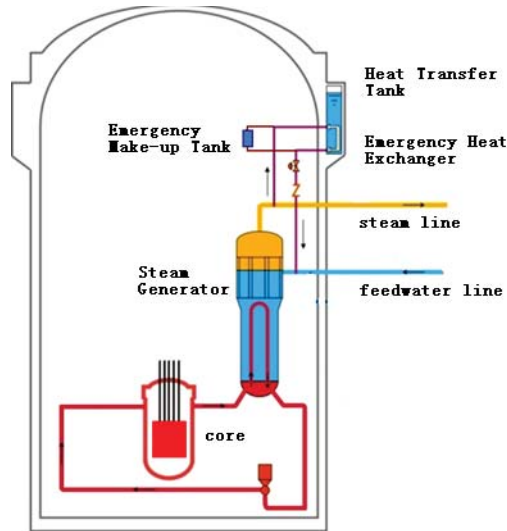

Figure 1 Schematic diagram of PRS

The PRS system consists of three trains associated to the RCS loops. Each train includes an Emergency Heat Exchanger, two Emergency Make-up Tanks, a Heat Transfer Tank and the necessary piping, valves and instruments.

Take example for the first train, the steam line equipped with a motor-driven valve connected to the main steam line penetrates through the containment and splits into two branches outer containment, one branch connects to the emergency heat exchanger and another one connects to the emergency make-up tanks. The emergency heat exchanger is seated on the bottom of the heat transfer tank and submerged in it, while the emergency make-up tanks are seated on the same level with the heat exchanger. The condensate line equipped with two parallel connected isolation valves from heat exchanger combined with the one from make-up tanks, which is equipped with two parallel connected isolation valves also, penetrates back the containment, and then connects to the feedwater line of steam generator. There is a check valve on the condensate line inner containment so as to avoid back flow of feedwater during normal operation.

The emergency residual heat removal heat-exchanger, which is immersed in accident cooling tank, is the key equipment of this system. The function of the heat exchanger is to transfer the heat of steam from steam generator to the water in accident cooling tank. The thermal design of emergency heat exchanger corresponds to the following operating conditions: tube-side pressure: 5.3MPa abs, inlet temperature: 267°C, outlet temperature: 75°C, flow rate: 6.2kg/s, sink temperature: 60°C.

As the final heat sink for PRS, the heat transfer tanks, shared with PCS, are located equally out of containment and integrated with the containment with a high level. The total volume of the tank (shared with 3 trains) is about 2300m³ which is designed to satisfy the requirement for operation in 72 hours.

The emergency make-up tank is designed mainly for making up the loss of water in steam generator secondary side because of the steam losing and the SG's secondary side density variety during the temperature decreasing.

3. ESPRIT FACILITY

Test facility called ESPRIT is built in CNNC, and some tests have been done to verify the running ability of the secondary passive residual heat removal system. The simulation factor of ESPRIT is 1/62.5. The main design parameters are as follows:

- ✓ the ratio for power and volume is 1:62.5;
- ✓ the elevation of the loop and the altitude difference between cold core and hot core are equaled to the Prototype;
- ✓ using the same working fluid;
- ✓ working fluid, pressure and temperature are same with the prototype;
- ✓ using the same friction coefficient for steam line and condensate line;
- ✓ the tube of SG is with the same outer diameter and spacing;
- ✓ using the same tubes and tube spacing, the number ratio is 1/62.5.

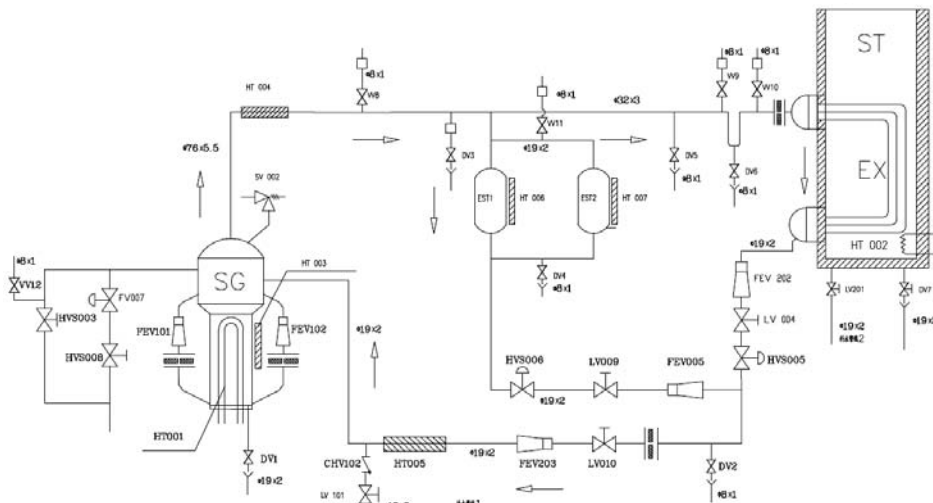

Figure 2 flow chart of ESPRIT facility

The test facility consists of the following systems: steam-water natural circulation system, pool heat removal system, steam emission branch and auxiliary systems.

Steam - water natural circulation system consists of an SG simulator, emergency makeup tank simulator, piping, valves, measurement devices and other components. There are many valves, such as condensate line manual control valve, condensate line quick open (off) valve, SG inlet pipe manual control valve, emergency make-up tank downstream quick open (off) valve, emergency make-up tank manual bypass valve and safety valve. The pipe of ESPRIT contains steam pipes, condensate pipes, the upstream and downstream pipes of emergency make-up tank.

The water in the pool is heated by fluid with high temperature in primary side of emergency heat exchanger simulator, which results natural convection in the pool. Finally, the heat is taken to the atmosphere by conduction, convection, evaporation and radiation.

Steam emission branch consists of Regulating valve, discharge steam bypass valve, the air bypass valve and the corresponding piping components. Two main functions: First, to achieve SG initial conditions

(including pressure and liquid level) established; the second is an analog prototype atmospheric discharge bypass valve. Auxiliary systems include water supply systems and pressure compensation system.

4. RELAP5 MODEL

RELAP5 v3.2 is used to simulate the tests. A basic analytical model of the test analysis is shown in Figure 3. It contains steam generator model, steam line model, heat exchanger model, condensate line model, emergency heat transfer pool model and make-up tank model.

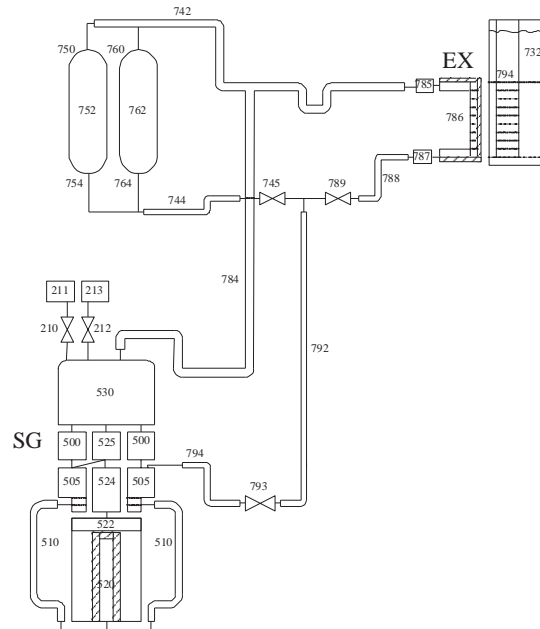

Figure 3 Analysis model of the facility

The area for heat transfer and the volume of steam generator are similar with the data of the facility. BRANCH 785 models inlet plenum of Heat Exchanger, BRANCH 787 models outlet plenum of Heat Exchanger. PIPE 786 models the fluid in the tubes. Heat Structure 786 models the tubes. The heat transfer condition uses default model in RELAP5.

Before the steady-state and transient tests, one case is carried out to ensure the resistance of the facility and prototype system are the same basically. The results show that the deviation is below 5%, and requirement for resistance is reached. The local loss coefficients of steam line and condensate line are adjusted to values of the facility.

Table 1 pressure drop of RELAP5 and the facility

| Pressure drop, kPa | RELAP5 | facility | deviation |
|--------------------|--------|----------|-----------|
| Steam line | 73.05 | 73.12 | -0.099% |
| Condensate line | 166.10 | 166.11 | -0.010% |

5. TEST ANALYSIS

5.1. STEADY-STATE TESTS

Steady-state tests are used to test the PRS operating characteristics at different heating power and different initial conditions. The initial conditions of four tests are listed in the table below.

Table 2 the initial conditions of four steady-state tests

| Test number | SG pressure, MPa | SG level, m | SG power, %FP |
|-------------|------------------|-------------|---------------|
| SS1 | 0.35 | 13.7 | 0.1 |
| SS2 | 0.35 | 13.7 | 0.5 |
| SS3 | 7.85 | 13.7 | 0.5 |
| SS4 | 7.85 | 13.7 | 0.8 |

The methods and steps of steady-state characteristic experimental are as follows:

- Filling with water and discharge the atmosphere;
- Isolate heat exchanger and make-up tank;
- Start the electric heater;
- After SG water level reached 13.7 m, calibrate the heat loss of SG simulator and steam line at different temperatures;
- Adjust the system pressure to 0.35 MPa, open the isolation valves located at condensate line. Fix the power at 0.5% FP. Make sure that the system is basically stable, complete SS2.
- Repeat e, comply SS1, SS3 and SS4.

Heat dissipation of the facility has a direct effect influence on tests. RELAP5 models do not simulate heat dissipation. Although heat dissipation is calibrated, the actual values for each test are not the same because the different weather conditions. In order to reduce the influence of this error, the enthalpy difference between import and export of the heat exchanger is as heat power of SG simulator, rather than test results.

Table 3 comparisons between tests and RELAP5

| parameters | SS1 | | SS2 | | SS3 | | SS4 | |
|--|-------|-------|-------|-------|-------|--------|-------|--------|
| | test | code | test | code | test | code | test | code |
| Power, kW | 52.0 | 62.2 | 250.9 | 259.4 | 249.6 | 269.0 | 426.9 | 434.7 |
| SG level, m | 13.07 | 13.06 | 13.62 | 13.62 | 13.78 | 13.64 | 13.78 | 13.76 |
| SG pressure, MPa | 0.21 | 0.167 | 0.53 | 0.485 | 0.515 | 0.500 | 0.915 | 0.964 |
| flowrate, kg/h | 0~398 | 100.0 | 430 | 432.5 | 442 | 449.4 | 692 | 690.3 |
| Inlet temperature of heat exchanger, °C | 113.7 | 112.1 | 145 | 142.5 | 142.9 | 143.4 | 168.8 | 172.53 |
| outlet temperature of heat exchanger, °C | 111.9 | 111.9 | 138.3 | 141.5 | 132.7 | 142.31 | 121.9 | 122.4 |

It can be found that the results of RELAP5 are consistent with tests. The calculated pressure increased faster than tests. The calculated pressure is lower in SS1, but it is higher in SS4.

5.2. TRANSIENT TESTS

Transient test is used to validate the operation ability of PRS system in 72 hours. Test process is divided into two steps. Step one: To establish initial condition of SG simulator, water level of 8.3 m, the pressure of 7.85 MPa. Step two: Close the pneumatic control valve to make the pressure increases. Once the pressure reaches 7.85 MPa, activate the PRS system immediately.

(1) 0s-about 800s

Steam is injected into the emergency make-up tank and inlet plenum of heat exchanger. The system pressure maintains at a high value, GCTa valve opens many times. During this period, the steam has not entered the tubes, the depressurization rate of transient test is greater than the value calculated by RELAP5 (Figure 4), the times GCTa valves open is less than results of RELAP5.

During the test, the steam with high flow rate injects into the top of make-up tank, and it greatly strengthens the condensation efficiency caused by direct contact condensation which will cause decrease the pressure of make-up tank. On the other hand, the empirical model of RELAP5 for direct contact condensation is developed based on that steam and water flow in the same flow direction and the steam is not injected directly into the water. The power calculated by the empirical model is lower than transient test. It can be proved in Figure 8 which shows that the temperature of top of make-up tank increases slower by RELAP5. As the condensation is intense, local pressure becomes low reasonably which makes the flowrate of make-up tank line lower (Figure 5).

(2) About 800s-about 3400s

The steam flows into the heat exchanger, depressurization rate becomes larger because condensation in the tubes is the major reason and direct-contact condensation almost disappears. At about 2400 s, the depressurization rate of test and calculated value by RELAP5 decrease. It is caused by change of heating power.

(3) About 3400s-72 hours

The flowrate of heat exchanger become larger after emptying of make-up tank (Figure 6). Before 8000 s, RELAP5 calculated pressure is lower than the test value, after 8000 s and they are basically identical. One peak of heat exchanger flowrate appears at about 6000s, which is due to the single-phase water discharges in outlet plenum. As two-phase flow appears in the condensate line close to heat exchanger, experimental values are unreal. The fluid in condensate line close to SG simulator remains single-phase because lower position, experimental values are real and consistent with the RELAP5 results.

— RELAP5 — test

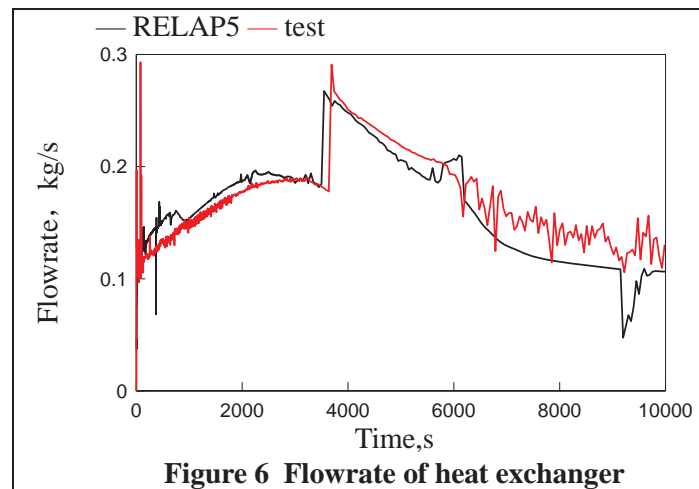
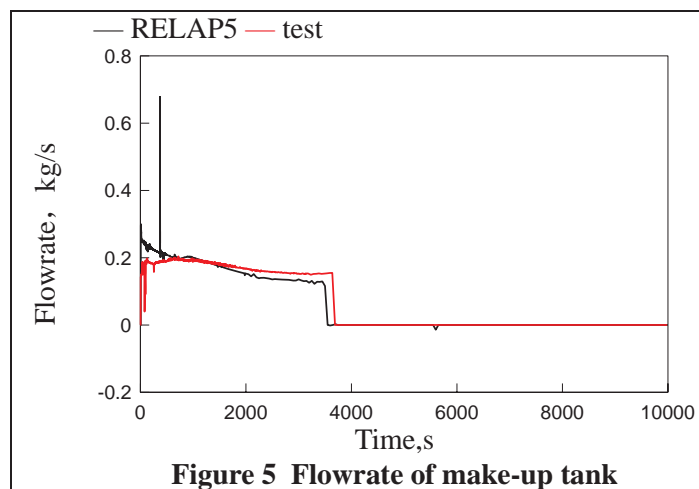
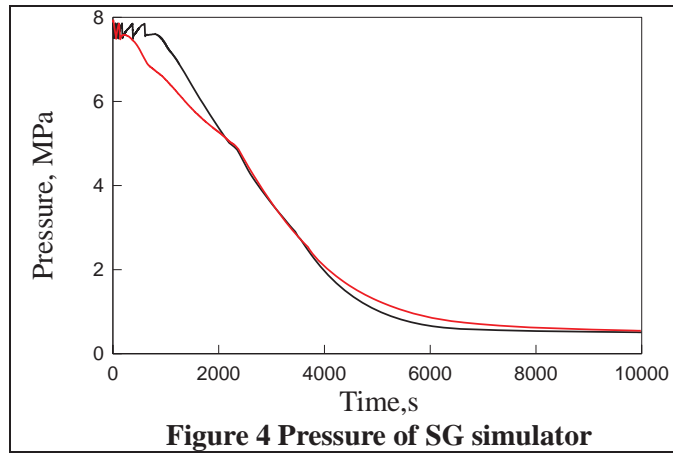

— RELAP5 — test

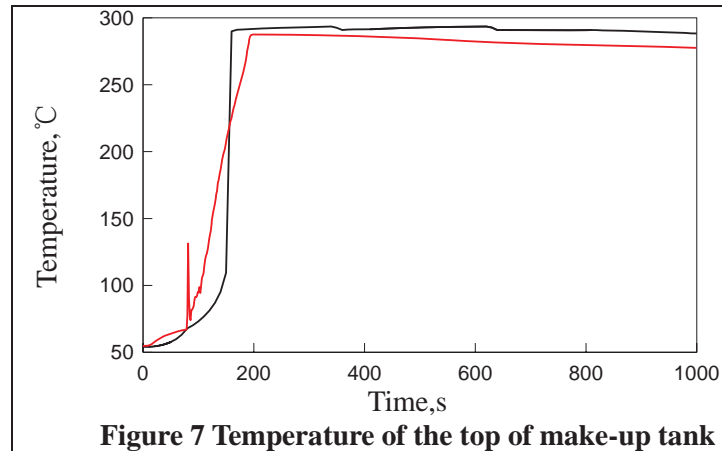

6. CONCLUSIONS

HuaLong I reactor is one 3rd generation reactor developed by CNNC. One major improvement is using three passive systems to mitigate Beyond Design Basis Accident. PRS system is one of them. PRS system is a secondary passive heat removal system, which removes the residual heat by SG secondary side. To verify the ability of PRS system, the test facility ESPRIT is built in Chengdu. Four Steady-states and one transient have been done. One model of RELAP5mod3.2 is developed and used to simulate the steady and transient tests. It can be found that:

- a) The results of RELAP5 show consistent with facility results;
- b) Steam pressure increases when the power increases. Compared to tests results, the code results increased more;
- c) RELAP5 could simulate two-phase natural circulation happened when PRS is activated. However once emergency make-up tank has come into service, the lack of the ability to simulate direct contact condensation will make the depressurization rate of RELAP5 lower.

REFERENCES

1. *RELAP5/MOD3 code manual*, NUREG/CR-5535, Idaho National Engineering Laboratory (1995).