

# A NATURAL CIRCULATION EXPERIMENT OF PASSIVE RESIDUAL HEAT REMOVAL HEAT EXCHANGER FOR AP1000

M. Duan, Y. Chen, Y. Lv, W. Li, K. Bi, W. Wang, K. Du

China Institute of Atomic Energy  
P.O.Box 275(59), Beijing, 102413, China  
chenyz@ciae.ac.cn

H. Wang

State Nuclear Power Technology Research & Development Centre

## ABSTRACT

The passive residual heat removal (PRHR) heat exchanger (HX) is an important emergency core cooling system of AP1000. In America, several tests for PRHR HX in AP600 have been performed to study the heat transfer behavior. However, the test section consisted of three vertical parallel tubes without horizontal sections. In the present test research, the PRHR heat exchanger was simulated by three C-type tubes, each of which had a middle vertical section, a top horizontal section and a bottom horizontal section with the same size and space as in AP1000.

The experiment purpose was to research the heat transfer behavior inside and outside of the HX tubes in different conditions. The test facility could control the test conditions including the primary system pressure, the inlet temperature of the HX tubes, the flow rate and the quality in tubes. The test conditions could vary in a quite wide range which could cover the operation conditions in AP1000.

Several natural circulation tests in HX tubes have been performed. The test parameters covered the pressure of 2.0 – 15.5 MPa, the quality up to 0.2, the inlet water temperature of 150 – 323 °C, the mass flow rate of 0.15 - 0.4 kg/s and the heating power of up to 364 kW. Hundreds of data have been obtained including the inner-tube water temperatures, the wall surface temperatures along the tubes, the pool water temperatures, the flow rate in tubes and so on. The experimental results were compared with the calculations by RELAP5/MOD3.3. The calculation results agreed well with the experiment.

## KEYWORDS

Natural circulation, PRHR HX, AP1000

## 1. INTRODUCTION

AP1000 reactor is the third generation pressurized water reactor. The passive residual heat removal (PRHR) heat exchanger (HX) is an important emergency core cooling system of AP1000, which can remove the core decay heat by the coolant natural circulation as a result of the different water density. The temperatures between two sides of the PRHR HX tubes differ greatly, and change in a wide range. Many kinds of single-phase and two-phase flow pattern and heat transfer modes are involved. Especially in natural circulation, the flow dynamic characters differ remarkably with the forced circulation because of the low flow rate and the great influence by buoyancy.

In America, several tests for PRHR HX in AP600 have been performed to study the heat transfer behavior. The HX was simulated by a test section which consisted of three vertical parallel tubes with no horizontal sections. The heat transfer has been researched between vertical tubes and the cooling tank [1]. However, a HX tube in AP1000 is in C shape and consists of a middle vertical section, a top horizontal section and a bottom horizontal section. A majority of heat is transferred through the top horizontal section. So it's necessary to simulate the natural circulation in HX tubes on a PRHR HX facility with C-type tubes and research the complicated thermo-hydraulics phenomenon.

In our research, the PRHR heat exchanger was simulated by three C-type tubes with typical sizes in AP1000. The experiment purpose was to research the heat transfer phenomena inside and outside of the HX tubes in different conditions and develop proper analysis method. The experiment conditions could vary in a wide range including the operation conditions in AP1000. The test facility could obtain data including the inner-tube water temperatures, the wall surface temperatures along the tubes, the pool water temperatures, the flow rate in tubes and so on. Several tests have been performed for natural circulation in tubes. And the experimental results were compared with the calculations by RELAP5/MOD3.3.

## 2. TEST FACILITY

The PRHR heat exchanger test facility was designed to perform heat transfer tests of both natural and forced circulation in HX tubes. The flow path of the test facility was designed as Figure 1. The main devices of the facility included a PRHR HX test section, a canned pump, a heater, a circulation pump, a heat exchanger in secondary side, a pressurizer, a high water tank, a low water tank, a lift pump, a make-up pump and a spray pump.

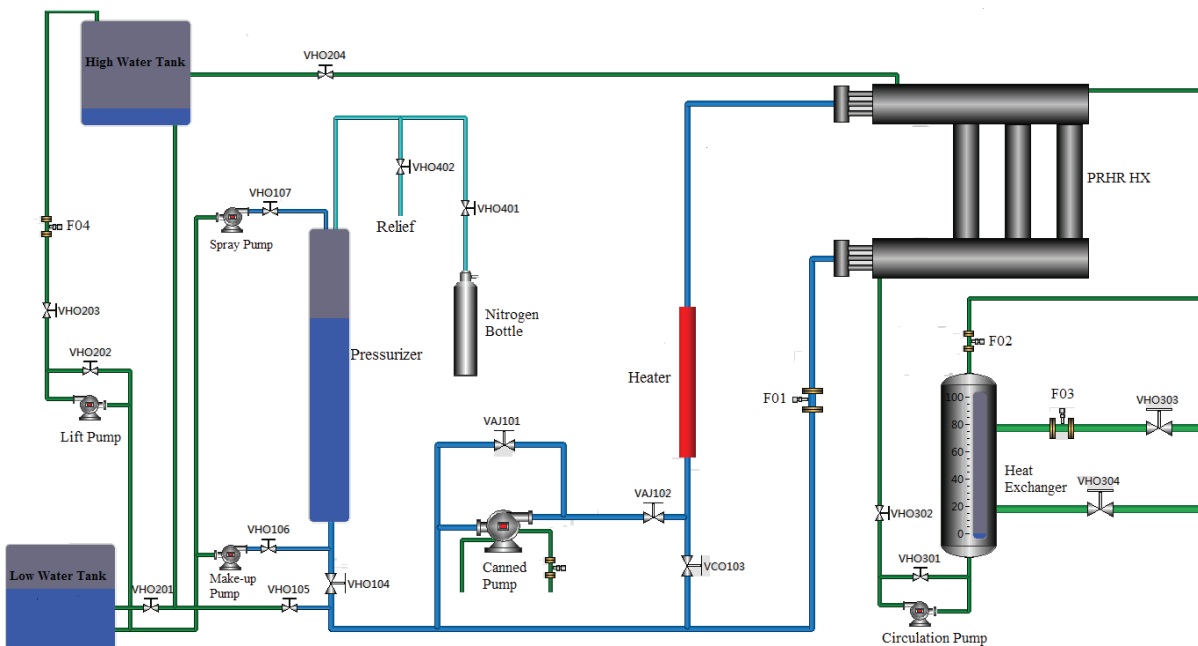

Figure 1. Flow Path Chart of the PRHR HX Test Facility

There were three C-type tubes in the facility with the same size as the ones in AP1000. According to AP1000, there are 688 HX tubes ( $\Phi 19.05 \times 1.65$ ) and the design coolant flow rate is  $2.28 \times 10^5$  kg/h. so the max design flow rate of three tubes should be 0.276 kg/s. In our facility, the design flow rate was up to

1.2 kg/s which could cover the typical flow rate of the PRHR. By adjusting the motor-driven valves VCO103, VAJ101 and VAJ102 in the primary loop, the system resistance could be controlled, so that the test flow rate could be changed. A mass flowmeter was installed in front of the heater to measure the flow rate in the primary loop.

In AP1000, the PRHR heat exchanger is operated in 15.5MPa, and the design pressure is 17 MPa. The inlet temperature of HX tubes is 297.2°C, while the outlet temperature is 92.8°C. The test facility preserved the full temperature and pressure conditions, and varied over the expected range for AP1000. The inlet water temperature could be adjusted by controlling the heating power of the heater. And the primary pressure was controlled by the pressurizer and the make-up pump.

The PRHR HX test section was the key device of the facility. It consisted of three C-type tubes, a cooling tank and instruments such as thermocouples. The C-type tubes immersed in the cooling tank which simulated the IRWST. When the high temperature water flowed through the tubes, the HX test section transferred the heat from the primary system to the cooling tank by heating and boiling the water in the tank.

The main technical parameters of the test section were shown as Table I.

**Table I. The main technical parameters of the HX test section**

Test Condition		Design Condition	
<b>Tank Pressure(MPa)</b>	0.1	<b>Tank Design Pressure(MPa)</b>	1
<b>Temperature in Tank(°C)</b>	~100	<b>Design Temperature in Tank(°C)</b>	100
<b>Tube Pressure(MPa)</b>	~15	<b>Tube Design Pressure(MPa)</b>	17
<b>Inlet Temperature of Tubes(°C)</b>	150~324	<b>Design Temperature in Tubes(°C)</b>	350
<b>Flow rate in each tube(kg/m2s)</b>	200~2000	<b>Fluid</b>	Deionized Water
<b>Tank Material</b>	06Cr19Ni10	<b>Tube Material</b>	Inconel 600

## 2.1. C-type Tubes

In the test section, the tube bundle consisted of three C-type tubes. The tubes were in the same vertical plane. Each tube contained a top horizontal section, a bottom horizontal section and a vertical section, which were connected to each other by cutting sleeves. The outer diameter of the test tube was 19.05 mm and the thickness was 1.65 mm as the HX tubes in AP1000 [2-4]. The heat transfer for vertical tubes has been researched, so this experiment mainly focused on the heat transfer in horizontal sections. Therefore, the space between horizontal tubes in AP1000 was conserved in the test section. The centerline-to-centerline space between adjacent horizontal tubes was 38mm. The tube lengths were shown in Table II. The tubes respectively simulated the shortest tube, the longest one and the center one of the PRHR HX tubes in AP1000. The material of the tubes was Inconel 600, while that in AP1000 was Inconel 690. There is 6 percent difference in the tube material thermal conductivity.

**Table II. The tube length**

Tube NO.	Horizontal Section Length	Vertical Section Length
A (shortest)	2586mm	5284mm
B (center)	3656mm	5360mm
C (longest)	4724mm	5436mm

The tubes were connected to the primary system pipes by two connectors as shown in Figure 2. A connector consisted of a vertical cylinder tank and four nozzles as shown in Figure 3. A top vertical nozzle was used for venting. Three horizontal parallel nozzles were used to connect with the HX tubes respectively. A single horizontal nozzle was used to connect with the primary pipe. The top connector was connected with the outlet line of the heater. The heated water flowed out of the heater and into the test section through the top connector, then out of the test section through the bottom connector. When the high temperature water flowed through the tubes, the C-type tubes transferred the heat from the primary system to the cooling tank by heating and boiling the water in the tank. The inner-tube natural circulation was developed from the density difference between the cold water in the outlet line and the hot water in the inlet line. The top connector was about 10.5m above lowest point of the test loop, so the max circulation height was 10.5m.

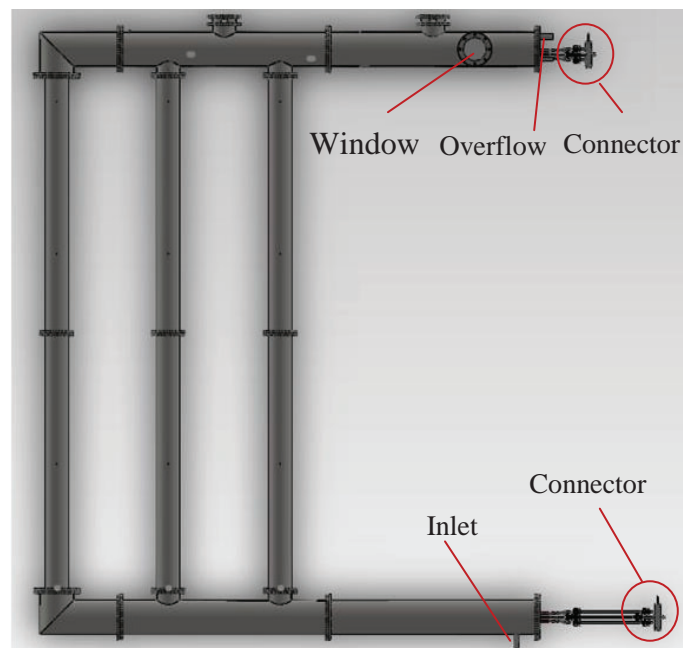
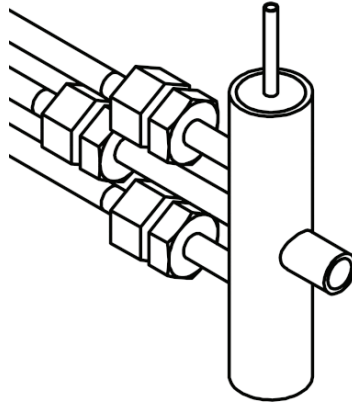

Figure 2. The Cooling Tank Configuration



**Figure 3. The Connector Configuration**

## 2.2. Cooling Tank

In America, several tests for PRHR HX in AP600 have been performed. The results indicated that when the space between adjacent tubes was large enough, the thermal effect was independent to each other. Typical pitch-to-diameter ration was 1.3 to 1.5, and in AP600 P/D was 2 for adjacent tubes. The tests also indicated that when the distance between the tube and the tank wall was large enough, the thermal effect by the tank wall could be ignored [1]. Therefore, in our test facility, the IRWST was predigested to a cylinder tubular tank, as shown in Figure 2.

The cooling tank consisted of three parallel vertical tubes connected to a top and bottom horizontal tube. Each vertical tube of the tank respectively contained one vertical section of the HX tubes, while the horizontal tube of the tank contained three horizontal sections of the HX tube bundle. The size of the horizontal tubes was  $\Phi 325 \times 3.5$ mm, and that of the vertical tubes was  $\Phi 219 \times 3.5$ mm. The distance between the tank wall and the HX tubes was much larger than 38mm, so the tank size wouldn't affect the heat transfer from the HX tubes to the cooling water, which meant that the predigested cooling tank was feasible.

The secondary cooling water flowed into the cooling tank from the inlet at the bottom, and left it from the outlet on the top flange cover. There was another outlet for the cooling water overflow. In order to observe the heat transfer phenomena in the tank, there were two windows on the tank.

## 2.3. Thermocouples

In the test section, many temperature data needed to be acquired, including the inner-tube water temperatures, the wall surface temperatures along the tubes and the pool water temperatures.

In order to measure the water temperature in tubes, several thermocouple traps were mounted into the tubes. A thermocouple trap was made of a  $\Phi 3 \times 0.5$ mm seamless stainless steel tube with one end closed and the other open. Several sheathed thermocouples of 0.5mm diameter were inserted into the trap from the open end. The thermocouple traps were inserted into and welded to the HX tubes, and supported in the centre of the tubes. By this way, it was assured that the thermocouples measured the centre temperature in the HX tubes. In order to minish the trap influence on the flow in HX tubes, the trap size should be as small as possible. However, there were 10 thermocouples to be installed in A tube, 12 in B tube, 13 in C tube. In order to contain so many thermocouples, the trap size was designed to be  $\Phi 3 \times 0.5$ mm. Because

of the thermocouple traps, the flow cross section in the HX tubes was reduced by 3.6%, which could be accepted.

Several thermocouples were welded on the outer wall surface of the HX tubes to measure the wall surface temperatures. There were 10 thermocouples on A tube, 14 on B tube, 13 on C tube. Each thermocouple on the wall surface was located between two thermocouples inside the HX tubes.

Besides, 18 thermocouple traps were inserted into and welded to the tank. One thermocouple was installed in each trap to measure the pool water temperatures.

### **3. TEST PROCEDURES**

Before the natural circulation test started, close valve VAJ101 and VAJ102 to isolate the canned pump from the test loop. Make sure valve VCO103 open. Open valve VHO202 and VHO203, and start the lift pump to pump the water in the low water tank to fill the high water tank. When the high water tank overflowed, shut down the lift pump, and turn off the valve VHO203. Turn on valve VHO105, VHO104 and VHO 204. Because of the gravity, water in the high water tank filled the test loop including the pressurizer, primary pipes and the cooling tank.

When the test loop was full of water, turn off valve VHO105. Feed nitrogen gas into the pressurizer, and start the make-up pump to increase the primary system pressure to the test condition. Then start the heater, which was a vertical pipe connected with the positive pole of DC power at the midpoint and with the negative pole at two ends. When the primary water flowed through the heater, its temperature rose and the density decreased, so the water flowed upwards into the test section. Adjust the heating power to make sure the inlet water temperature of the test section reached the test condition. Adjust the motor-driven valve VCO103 to change the system resistance and control the flow rate in the primary loop. When the hot water flowed through the test section, it was cooled by the cooling tank. The water density increased, so the water flowed downwards and back into the heater. This course formed the natural circulation in the primary loop. Meanwhile, start the circulation pump to circulate the water in the cooling tank through the secondary heat exchanger, and turn on valve VHO303 and VHO304 to cool the tank water.

The natural circulation test in HX tubes was a steady test. When the primary water temperature was under the saturation temperature, there was single-phase flow in the primary loop. In this case, the natural circulation in HX tubes was stable. If the water out of the heater was supersaturated, there was two-phase flow in the HX tubes. The primary system pressure fluctuated strongly. In this case, turn down valve VCO103 to increase the system resistance. When the system resistance was large enough, the primary pressure stopped fluctuating and the system became stable.

When the system was stable, the computer began to record the test data every second including the inner-tube water temperatures, the wall surface temperatures along the tubes, the pool water temperatures, the flow rate in the primary loop, the heating power and so on.

### **4. TEST RESULTS AND ANALYSIS**

The purpose of the PRHR tests was to provide a database to research the heat transfer behavior inside and outside of the PRHR tubes. In our tests, the parameters covered the primary pressure of 2.0 - 15.5 MPa, the quality in tubes up to 0.2, the inlet water temperature of 150 - 323 °C, the mass flow rate of 0.15 - 0.4 kg/s and the heating power of up to 364 kW. The test conditions could cover the operation range for PRHR HX in AP1000. In all tests, the system could achieve a steady state. Even if there was two-phase flow inside tubes, the system pressure and the natural circulation flow rate in tubes were stable.

The PRHR heat exchanger had several different modes of heat transfer. When the power of the heater was not large enough, water out of the heater couldn't achieve the saturation temperature. So the heat transfer inside the HX tubes was natural convection. When the power was large enough, the primary water out of the heater was supersaturated. So the heat transfer was nucleate boiling inside tubes. Outside the tubes, the heat transfer was boiling and natural convection in pool. RELAP5/MOD3.3 has been used to model the test facility, simulate the heat transfer inside and outside of the HX tubes and assess the calculation model. There were 3 inner-tube natural circulation test conditions calculated in Table III.

**Table III. Test conditions**

NO.	Pressure(MPa)	Heating Power(kW)	Inlet Temperature(°C)	Mass Flow Rate(kg/s)	Quality(xi)
FN01	15.5	364	322	0.363	-0.16
FN02	8.5	228	272	0.292	-0.10
FN03	6.5	203	281	0.179	0.17

#### 4.1. Heat Transfer in the Tube

The heat transfer was natural convection or nucleate boiling in the HX tubes depending on the heating power. In RELAP5, the heat transfer coefficient could be calculated by Dittus-Boelter correlation for single-phase liquid turbulent forced convection [5-7], which is given as:

$$Nu_{DB} = \frac{h_{DB} D_i}{k_i} = 0.023 Re^{0.8} Pr^{0.3} \quad (1)$$

Where  $D_i$  means the inside tube diameter,  $k_i$  means the fluid thermal conductivity, Re means the fluid Reynolds number, Pr means the fluid Prandtl number.

Dittus-Boelter correlation could be applied within the range of parameters:  $0.7 < Pr < 160$ ,  $Re > 6000$ ,  $\frac{L}{D_i} > 60$  (L is the tube length).

In our tests, Prandtl number was between 0.8 and 3.2, Reynolds number was above 18000, and  $\frac{L}{D_i} > 300$ .

Though it was natural circulation in tubes, the Reynolds number was very large. Therefore, it was turbulence in tubes, and Dittus-Boelter correlation was chosen in RELAP5 for heat transfer coefficient calculation in these test conditions.

In RELAP5, the heat transfer coefficient could be calculated by Chen correlation for nucleate boiling [5, 7], which is given as:

$$h_{TP} = h_{NB} + h_{FC} \quad (2)$$

Where  $h_{NB}$  means the nucleate boiling heat transfer coefficient,  $h_{FC}$  means the convection heat transfer coefficient which could be calculated by Dittus-Boelter correlation.

In RELAP5, input the pressure, inlet temperature, the heating power, the mass flow rate and the pool temperature distribution as the boundary conditions, the inner-tube temperature distribution along the tube length could be calculated. The calculation results of three tubes have been shown in Figure 4-6.

From the results, it can be indicated that the major heat transfer took place at the horizontal section of the tubes. Along the tube length, the inner-tube temperature decreased because of the secondary cooling water. Near the inlet, the fluid temperature was high, the heat transfer coefficient and the heat flux were large, so the primary temperature decreased quickly. Along the tube length, the heat flux decreased and the inner-tube temperature dropped gradually slowly. Also, in the horizontal section, the temperature of the upper water tank was higher than the bottom, so the heat flux of the upper tube was smaller than the bottom tube. The inner-tube temperature of the upper tube was higher than the bottom one at the same distance from the inlet.

The comparison between the test data and the calculation results indicated that in both single-phase and two-phase heat transfer conditions, the calculated inner-tube temperatures of three HX tubes agreed well with the test data. Therefore, it can be concluded that Dittus-Boelter and Chen correlations could be applied in RELAP5 to calculate the heat transfer inside the tubes within the test conditions.

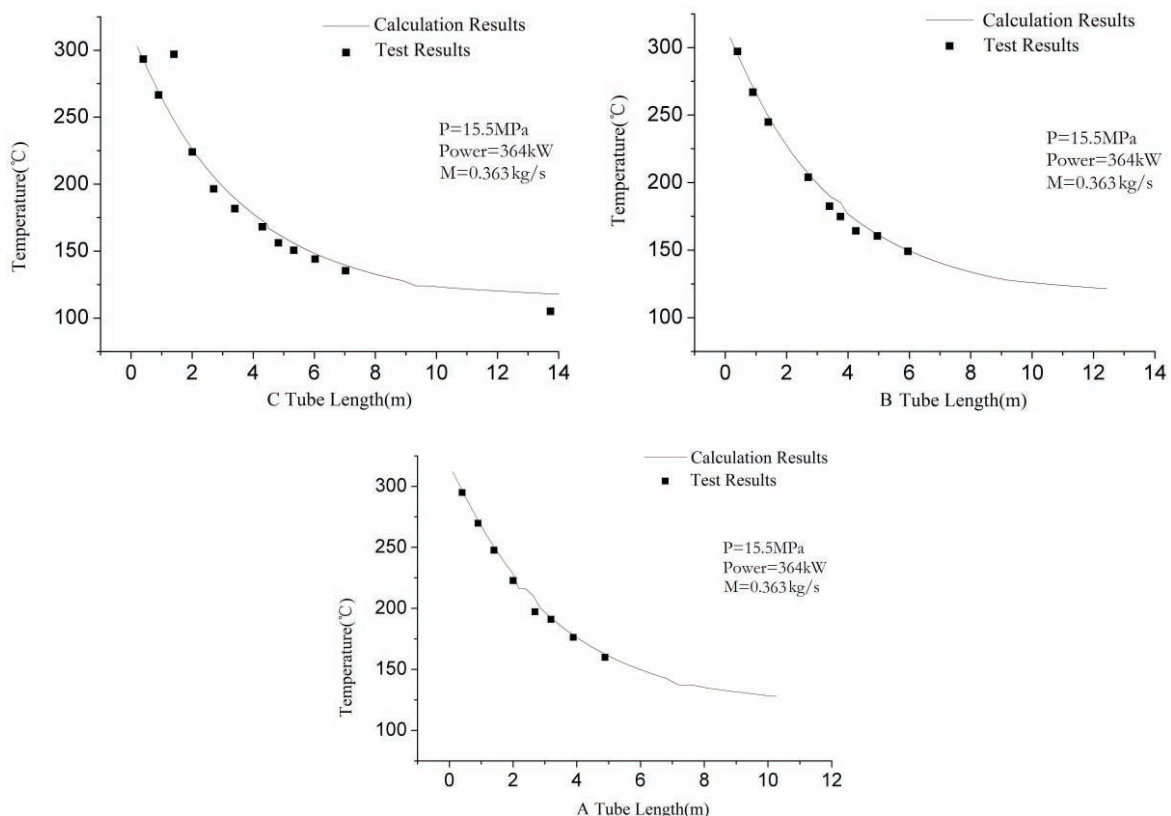

Figure 4. The Inner-tube Temperature Comparison of FN01Test



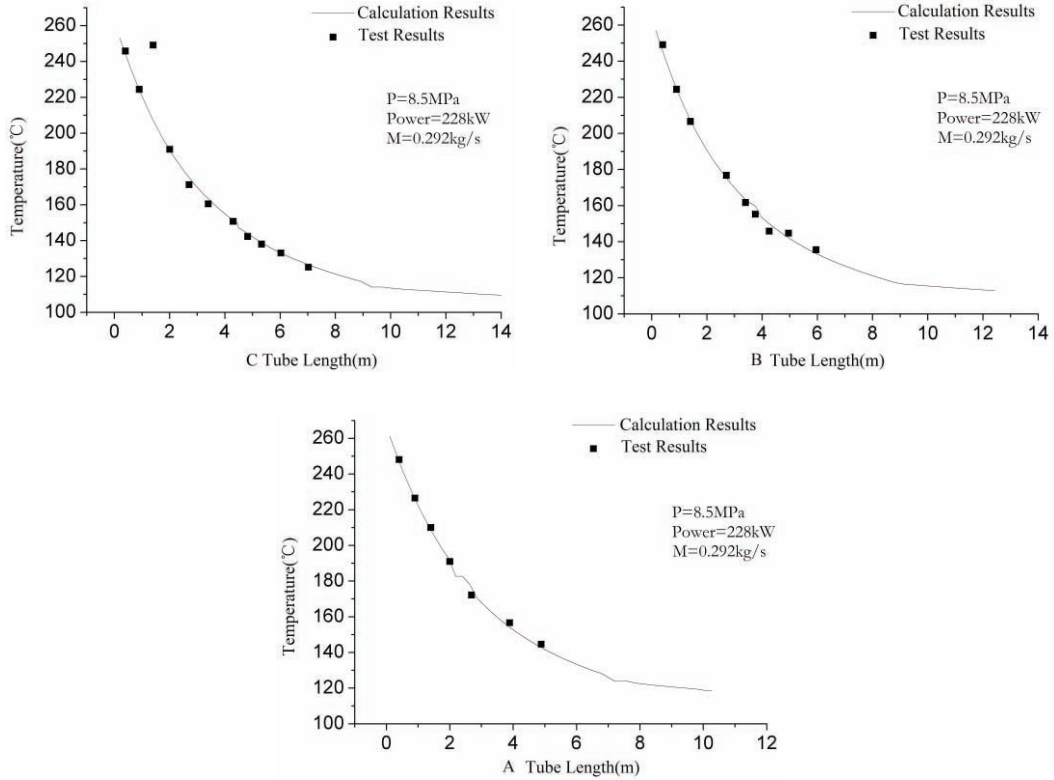

Figure 5. The Inner-tube Temperature Comparison of FN02Test

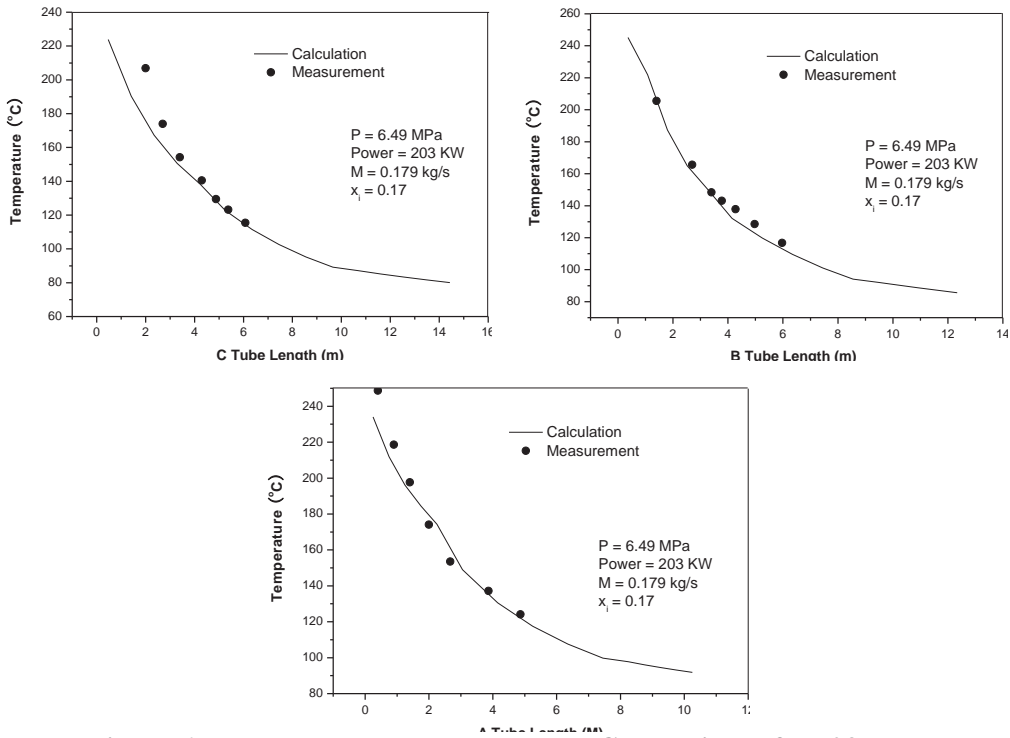

Figure 6. The Inner-tube Temperature Comparison of FN03Test

## 4.2. Heat Transfer in the Cooling Tank

There were two heat transfer modes outside of the HX tubes: boiling and natural convection, which depended on the tube-wall temperature. Boiling occurred at the horizontal sections of the HX tubes. Near the HX tube inlet, the tubes had sufficient wall superheat ( $T_{wo} - T_s$ ), so the local nucleate boiling occurred. Along the tube length, the wall temperature dropped because of the secondary cooling water. When the wall superheat wasn't large enough, boiling didn't occur. Considering the large volume of the tank, the flow rate in the secondary circulation was very small, so the heat transfer mode could be considered to be natural convection in large room.

The local wall heat flux could be calculated by the steady-state energy balance equation as below:

$$q_{w_i} = \frac{\dot{m}(H_i - H_{i+1})}{\pi D_i \Delta L_i} \quad (3)$$

Where  $q_{w_i}$  means the local wall heat flux,  $\dot{m}$  means the inner-tube mass flow rate,  $H_i$  means the local fluid enthalpy at position  $i$  which was determined by the inner-tube temperature,  $\Delta L_i$  means the distance between two inner-tube temperature measure positions  $i$  and  $i+1$ .

The boiling heat transfer coefficient could be calculated by Chen correlation as mentioned above. The boiling heat transfer curve could be correlated by the local wall heat flux and the wall superheat  $T_{wo} - T_s$  as Figure 7. The calculation results by RELAP5 were also shown in it. Generally speaking, the calculation trend agreed well with the test data. At low superheat region, the calculated heat flux was close to the test data. At high superheat region, the calculated heat flux was higher than the test data. When the local wall heat flux increased largely, the wall superheat increase slowed down. The wall superheat was less than  $30^\circ\text{C}$ . Compared with the large temperature difference between the inner-tube water and the cooling tank water, the temperature difference in the tank water was relatively small. Therefore, Chen correlation was enough to calculate the boiling heat transfer in the test conditions.

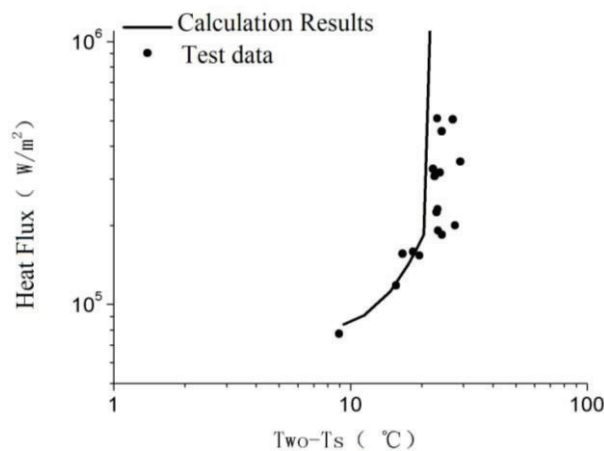
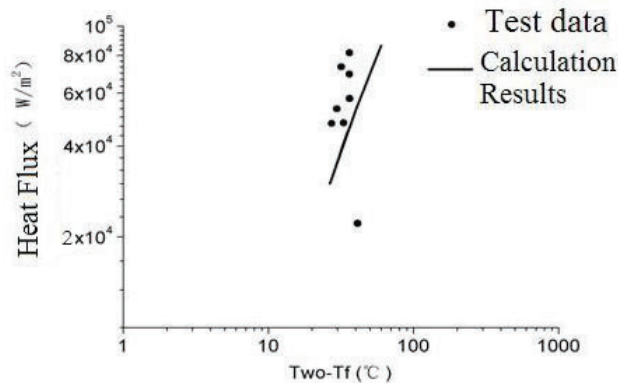

Figure 7. The Boiling Heat Transfer Curve in the Cooling Tank

The natural convection heat transfer coefficient could be calculated by Churchill-Chu and McAdams correlation in RELAP5 [5]. The natural convection heat transfer curve could be correlated by the local wall heat flux and the difference between the wall temperature and the secondary temperature ( $T_{wo} - T_f$ ) as Figure 8. The calculation results were also shown in it. The calculated heat flux was lower than the test data, and the calculation trend agreed well with the test data.



**Figure 8. The Natural Convection Heat Transfer Curve in the Cooling Tank**

## 5. CONCLUSIONS

According to the inner-tube natural circulation experiment research of PRHR HX for AP1000, it can be concluded that: a) A PRHR heat exchanger test facility with 3 typical C-type HX tubes of AP1000 has been built. It can simulate the natural circulation in HX tubes under the pressure of 2.0-15.5MPa, the quality up to 0.2, the inlet water temperature of 150-323 °C and the flow rate of 0.15-0.4kg/s, which could cover the operation range in AP1000. b) The experiment provided hundreds of data to research the heat transfer behavior inside and outside of the C-type tubes. c) RELAP5 could be applied with proper correlations to analysis the thermal transfer in PRHR heat exchanger under the test condition.

## ACKNOWLEDGMENTS

This research was supported by Large Advanced PWR Plant National Science and Technology Major Project (2011ZX06004-007-001).

## REFERENCES

1. L.E.Hochreiter, F.E.Peters and D.L.Paulsen, "AP600 Passive Residual Heat Removal Heat Exchanger Test Final Report," 1997.4.
2. Lin Chengge and Yu Zusheng, *An Advanced Passive Plant AP1000*, 2008.1.
3. RRYES J. and WOODS B., "Testing of Passive Safety System Performance for Higher Power Advanced Reactors". US: Oregon State University, 2004.
4. SCHULZ T L., "Westinghouse AP1000 advanced passive plant," *Nuclear Engineering and Design*, 2006.
5. Information Systems Laboratories, Inc., *RELAP5/MOD3.3 Code Manual. Volume IV: Models and Correlation*, December 2001.

6. Corletti, M. M., Hochreiter, L. E. and W. A. Stewart, "AP600 Passive Residual Heat Removal Heat Exchanger Test, Final Report, WCAP-12980-Rev. 0," December 1991.
7. Hao Laomi. *Boiling Heat Transfer and Gas (Vapor)-Liquid Two-phase Flow*, August 2007.